

5003 Series Thermostat

The Airpax 5003 series is a RoHS compliant, thin, lightweight, wafer-type thermal switch that is ideal for applications when space is at a premium. Overall depth without projecting terminals is only 0.250 inches.

The basic switch assembly is operated by a bimetal disc with positive, reinforced snap-action, which is known for its reliable repeatability. The construction of the switch assembly offers excellent shock and vibration resistance. Thermal response is fast due to low mass.

For high humidity and contaminating atmosphere applications, the device can be sealed with a non-volatile resin. Narrow differential devices are ideal for control, while standard differentials can be used for high or low temperature limit switches. The series 5003 thermostat is cRUus certified.

SPECIFICATIONS

■ *Contact Ratings for 100,000 Life Cycles:

- 5 amp resistive, 120VAC
- 3 amp resistive, 240VAC, 24VDC
- 1.5 amp resistive, 48DVC

■ Contacts:

SPST (Single Pole, Single Throw)

■ Operating Temperature Settings:

+35°F to 325°F (1.67°C to 162.78°C)

■ Dielectric Strength:

1500VRMS 60Hz, 1 minute, terminals to case

■ Weight:

2.3 grams (0.08 oz)

■ Long Term Exposure Limit:

-40°F to 350°F (-40°C to 176.67°C)

* cRUus certified to 168°C operating temperature. Loads under 100mA, 5Vdc, will require gold-plated contacts, with recommended minimum load of 10mA, 5Vdc.

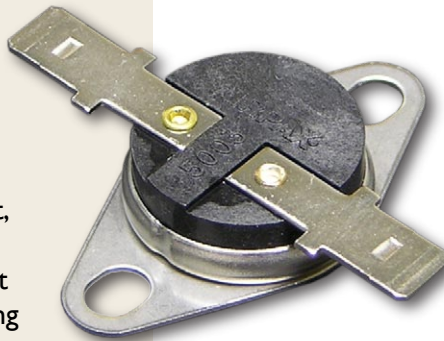

AIRPAX

© Copyright 1999-2007 Airpax • All Rights Reserved • 245-500-6010 • 0607





5003 PART NUMBER BUILDER

1. Contact Operation Codes	
CODE	DESCRIPTION
O	Letter "O" = Open on Rise
C	Letter "C" = Close on Rise

To build your 5003 part number (PN), choose the proper code* from the tables on pages 2 thru 4.

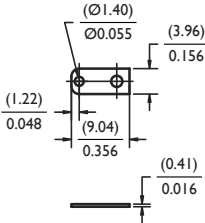
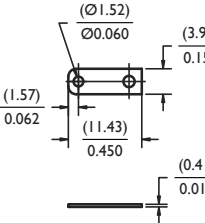
Consult the Airpax Sensors & Control Systems - Frederick Division when a code Z is used to indicate a special requirement. Airpax will assign a unique, customer-specific four digit nondescript number. To complete the customer specific part number build, replace the bottom temperature and tolerance (codes 7 & 8) after the "-" dash with this four digit nondescript.

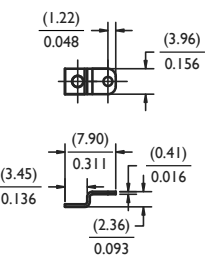
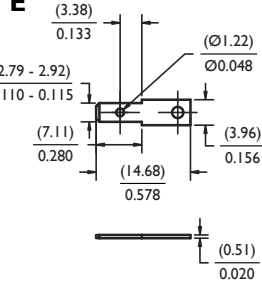
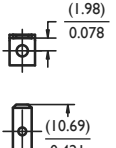
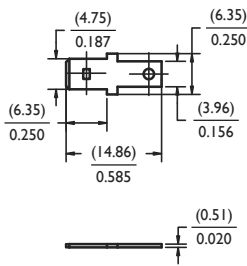
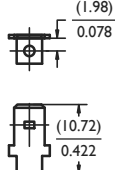
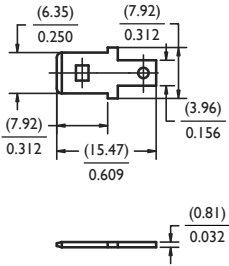
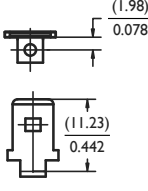
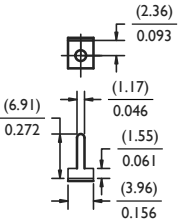
2. Terminal Selection Codes

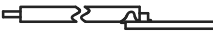
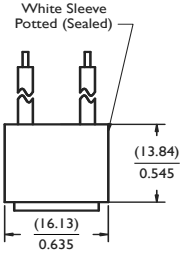
<p>A</p> 	<p>B</p> 	<p>C</p>  <p>Same as View "B" Except Formed 90°</p>	<p>D</p> 	<p>E</p> 
<p>F</p>  <p>Same as View "E" Except Formed 90°</p>	<p>G</p> 	<p>H</p>  <p>Same as View "G" Except Formed 90°</p>	<p>J</p> 	<p>K</p>  <p>Same as View "J" Except Formed 90°</p>
<p>L</p> 	<p>M</p> <p>2 Leads $\frac{(152.40 \pm 6.35)}{6.000 \pm 0.250}$</p> <p>See notes i & ii for lead wire specifications</p> 	<p>R</p> <p>2 Leads $\frac{(152.40 \pm 6.35)}{6.000 \pm 0.250}$</p> <p>See notes i & ii for lead wire specifications</p> 	<p>U</p> <p>2 Leads $\frac{(152.40 \pm 6.35)}{6.000 \pm 0.250}$</p> <p>See notes i & ii for lead wire specifications</p>	<p>V</p> <p>Same as terminal selection "U"</p> <p>Except 2 Leads $\frac{(304.80 \pm 12.70)}{12.000 \pm 0.500}$</p> <p>See notes i & ii for lead wire specifications</p>
<p>NOTES :</p> <p>The standard lead wire materials for different temperature ranges are as follows :</p> <p>i. Up to 220°F (104.4°C): #18 stranded UL 1015 AWN and CSA TEW approved, black PVC insulation</p> <p>ii. 221°F to 350°F (105°C to 176.6°C): #18 stranded black 'type I' TFE, Teflon® insulation per MIL-W-22759</p>	<p>N</p> <p>Same as terminal selection "M"</p> <p>Except 2 Leads $\frac{(304.80 \pm 12.70)}{12.000 \pm 0.500}$</p> <p>See notes i & ii for lead wire specifications</p>	<p>S</p> <p>Same as terminal selection "R"</p> <p>Except 2 Leads $\frac{(304.80 \pm 12.70)}{12.000 \pm 0.500}$</p> <p>See notes i & ii for lead wire specifications</p>	<p>White Sleeve Potted (Sealed)</p> 	<p>W</p> <p>Same as terminal selection "U"</p> <p>Except 2 Leads $\frac{(609.60 \pm 19.05)}{24.000 \pm 0.750}$</p> <p>See notes i & ii for lead wire specifications</p>
	<p>P</p> <p>Same as terminal selection "M"</p> <p>Except 2 Leads $\frac{(609.60 \pm 19.05)}{24.000 \pm 0.750}$</p> <p>See notes i & ii for lead wire specifications</p>	<p>T</p> <p>Same as terminal selection "R"</p> <p>Except 2 Leads $\frac{(609.60 \pm 19.05)}{24.000 \pm 0.750}$</p> <p>See notes i & ii for lead wire specifications</p>		<p>Z</p> <p>Special Requirements Customer to Specify</p>

Example : **C53GAB I 05 A - 09 0 Y**

Close contacts on temperature rise, 5003 series, 0.25" horizontal quick-connects with opposed orientation, 0.140" two hole mounting bracket, 105°F top temperature with a ±5°F standard top tolerance and a standard 15°F differential between top and bottom temperature for temperature range of 35°F to 200°F, differential helps calculate a bottom temperature of 90°F with a standard minimum reset for contacts to open at or above the bottom temperature setpoint.

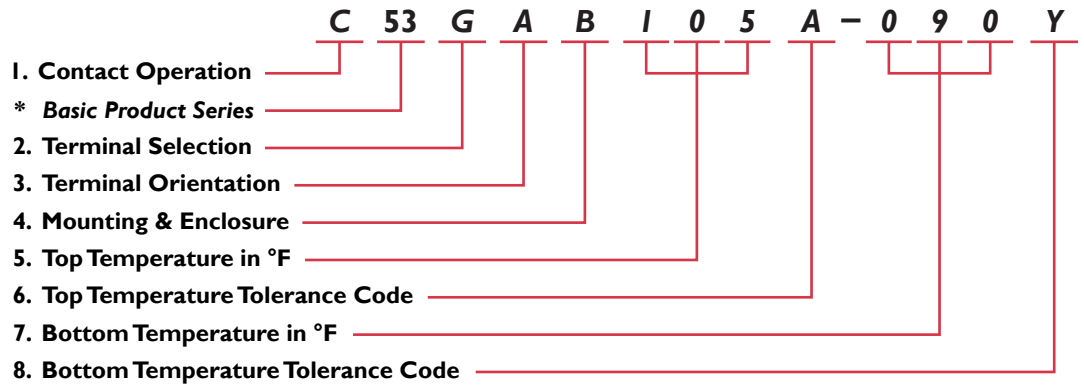

3. Terminal Orientation Codes

<p>A</p> <p>OPPOSED - Terminals on opposite sides of thermostat, on a parallel plane to the mounting bracket / base</p>	<p>B</p> <p>PARALLEL - Terminals on same side of thermostat, on a parallel plane to the mounting bracket / base</p>	<p>C</p> <p>VERTICAL - Both terminals extend up and away, on a perpendicular plane to the mounting bracket / base</p>	<p>Z</p> <p>Special Requirements Customer to Specify</p>	<p>NOTES :</p> <p>Terminal orientation restrictions :</p> <ul style="list-style-type: none"> · 'A' (Opposed) = terminals allowed are A, B, E, G, J, R to T, Z · 'B' (Parallel) = terminals allowed are A, B, E, R to T, Z · 'C' (Vertical) = terminals allowed are C, D, F, H, K to P, U to Z
--	--	--	---	---

4. Mounting and Enclosure Selection Codes

<p>A</p>	<p>B</p> <p>2 Mounting Slots</p>	<p>C</p>	<p>D</p>	<p>E</p>
<p>F</p>	<p>G</p>	<p>H</p> <p>6-32 UNC-2A Thread</p> <p>Undercut to Allow Stud to Screw Down Flat</p>	<p>J</p> <p>8-32 UNC-2A Thread</p> <p>Undercut to Allow Stud to Screw Down Flat</p>	<p>Z</p> <p>Special Requirements Customer to Specify</p>

5. Top Temperature in °F

	°F	°C	°F	°C	°F	°C
Temperature Setting	35°F to 200°F	1.6°C to 93°C	201°F to 300°F	94°C to 149°C	301°F to 325°F	150°C to 163°C
Standard Tolerance	±5°F	±2.8°C	±8°F	±4.4°C	±10°F	±5.6°C
Nominal Differential	15°F	8.3°C	25°F	13.8°C	30°F	16.7°C

NOTES:

- Select any temperature in the range of 35°F to 325°F. Standard choices fall on the 5°F increments, for example 35°F, 40°F, 45°F, 50°F... up to 320°F or 325°F
- Specify the °F temperature in the part numbering scheme as a three digit code without the “°F” in the part number. For example, for 90°F, put in code ‘090’

6. Top Temperature Tolerance Codes

CODE	A	B	C	X	Z
± °F	±5°F	±8°F	±10°F	Maximum	Customer to Specify
± °C	±2.8°C	±4.4°C	±5.6°C	Maximum	Customer to Specify

NOTES:

- The standard tolerance for the top temperature is based on the temperature range the top temperature falls in, please refer to “5. Top Temperature in °F” chart, and select the appropriate code for a standard top temperature tolerance.

7. Bottom Temperature in °F

“Bottom Temperature in °F” equals the “Top Temperature in °F” minus the “Nominal Differential in °F for that temperature”.

Example 1: 50°F – 15°F = 35°F **Example 2:** 250°F – 25°F = 225°F **Example 3:** 310°F – 30°F = 280°F

NOTES:

- Specify the °F temperature in the part numbering scheme as a three digit code without the “°F” in the part number (example 90°F, put in the code as ‘090’)

8. Bottom Temperature Tolerance Codes

CODE	A	B	C	Y	Z
± °F	±5°F	±8°F	±10°F	Minimum	Customer to Specify
± °C	±2.8°C	±4.4°C	±5.6°C	Minimum	Customer to Specify

NOTES:

- The typical standard bottom temperature tolerance is a ‘Y’ = minimum trip, which indicates the “reset” trip occurs at or above the lower temperature set point.
- The other standard tolerances are based on the temperature range the bottom temperature is in. The most convenient solution is to use either the ‘Y’ minimum reset code or choose the same tolerance code selection used in “6. Top Temperature Tolerance Code”.

